

AURA

PACKAGER SERIES HARD SEAT NEEDLE VALVES

SIZES	:	1/4", 1/2" and 3/4 x 1/2"						
BODY	:	Forged single piece CS, ASTM A-105 plated or ASTM A182 F 316 SS Brass Straight Pattern						
END CONNECTIONS	:	Screwed						
STEM	:	Close tolerance surface finish, cold rolled threads, ASME SA-479 Type 316 SS						
NEEDLE TIP	:	Hardened & Ground.						
UPPER/LOWER GLAND BODY	:	SS locking pin provided. CS, ASTM A108 plated or ASME SA-479 Type 316 SS						
GLAND PACKING	:	PTFE						
HANDLE	:	'T' bar handle. CS, ASTM A108 plated or ASME-SA-479 Type 316 SS						
WASHER	:	ASME-SA-479 Type 316 SS						
PRESSURE/TEMPERATURE	:	<table><thead><tr><th><u>TEMPERATURE</u></th><th><u>PRESSURE</u></th></tr></thead><tbody><tr><td>200 °F</td><td>6,000 psi</td></tr><tr><td>500 °F</td><td>4,000 psi</td></tr></tbody></table>	<u>TEMPERATURE</u>	<u>PRESSURE</u>	200 °F	6,000 psi	500 °F	4,000 psi
<u>TEMPERATURE</u>	<u>PRESSURE</u>							
200 °F	6,000 psi							
500 °F	4,000 psi							
TEST PRESSURES	:	Body: Hydrostatic at 6,000 psi Seat – 1,000 psi with Nitrogen						

REV.	REASON FOR ISSUE.	DATE	DRN.	CHKD.
0.00	REL. FOR MANU.	12.16.03	D.K.D	G.G.A
1.00	WGI DRAWING	01.19.04	D.K.D	G.G.A

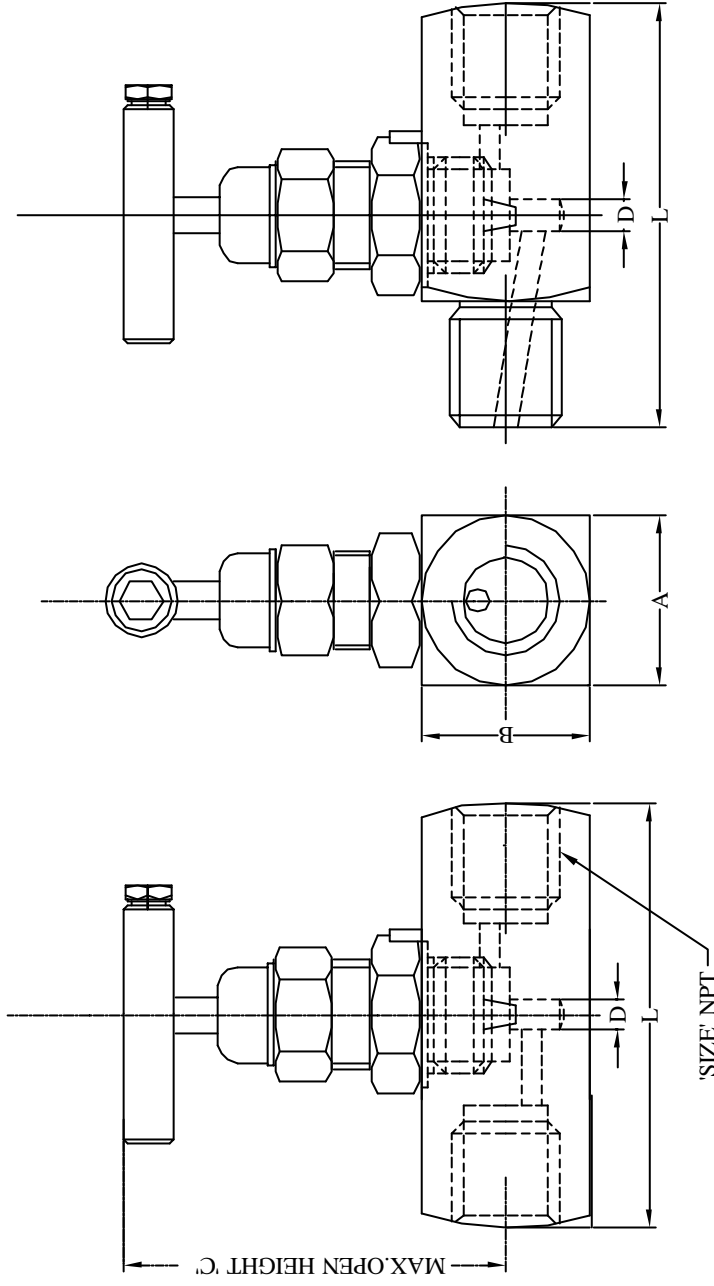

PROJECT/CLIENT		Aura Inc. D11/3,OKHALA IND. AREA, PHASE II, NEW DELHI INDIA. www.aurainc.com	
TITLE		PACKAGER HARDSEAT NEEDLE VALVE	
PRESSURE RATING	6,000PSI	ALL DIMENSIONS ARE SUBJECT TO CHANGE WITHOUT PRIOR NOTICE .TO BE USED FOR REFERENCE ONLY. UNAUTHORIZED REPRODUCTION IS PROHIBITED.	
TEMPERATURE RATING	200° F		
PATTERN 'A' =ANGLED, 'G' =STRAIGHT			
DRG. NO : AI -PNV -001		SHEET 1 OF 2	

REV.	REASON FOR ISSUE.	DATE	DRN.	CHKD.
0.00	REL. FOR MANU.	12.16.03	D.K.D	G.G.A
1.00	WGI DRAWING	01.19.04	D.K.D	G.G.A

PART NO.	SIZE	PATTERN	ENDS	MATL	A	B	C	L	D
AN1612P	1/4"	G	FF	CS	22.0	22.0	74.0	54.0	3.2
AN1632P	1/4"	G	MF	CS	22.0	22.0	74.0	54.0	3.2
AN1612PN	1/4"	G	FF	CS NACE	22.0	22.0	74.0	54.0	3.2
AN1632PN	1/4"	G	MF	CS NACE	22.0	22.0	74.0	54.0	3.2
AN1412P	1/4"	G	FF	316SS	22.0	22.0	74.0	54.0	3.2
AN1432P	1/4"	G	MF	316SS	22.0	22.0	74.0	54.0	3.2
AN1614P	1/2"	G	FF	CS	28.5	28.5	68.0	76.0	03.2
AN1614PN	1/2"	G	FF	CS NACE	28.5	28.5	68.0	76.0	03.2
WN1634P	1/2"	G	MF	CS	28.5	28.5	68.0	76.0	03.2
AN1634PN	1/2"	G	MF	CS NACE	28.5	28.5	68.0	76.0	03.2
AN1414P	1/2"	G	FF	316SS	28.5	28.5	68.0	76.0	03.2
AN1434P	1/2"	G	MF	316SS	28.5	28.5	68.0	76.0	03.2
AN1637P	3/4"x1/2"	G	MF	CS	30.0	30.0	70.0	76.0	4.0
AN1637PN	3/4"x1/2"	G	MF	CS NACE	30.0	30.0	70.0	76.0	4.0
AN1437P	3/4"x1/2"	G	MF	316SS	30.0	30.0	70.0	76.0	4.0

ALL DIMENSIONS ARE IN MM.

ALL DIMENSIONS ARE SUBJECT TO CHANGE WITHOUT PRIOR NOTICE, TO BE USED FOR REFERENCE ONLY.

PROJECT/CLIENT

TITLE	PACKAGER HARDSEAT NEEDLE VALVE
--------------	-------------------------------------------

Aura Inc.
D11/3,OKHALA IND. AREA,
PHASE II, NEW DELHI
INDIA.
www.aurainc.com

DRG. NO :AI- PNV-001

This drawing is the property of Aura, Inc. Unauthorized reproduction is prohibited.